

Figure 1

Setting the Downstream Laser Optical Modulation Index for Optimum Performance.

Modern HFC cable plants require careful setting of the signal levels in order to ensure optimal performance of the downstream plant. One area that requires particular attention is correctly setting the levels of both Analog and Digital signals prior to modulation on a laser. This application note discusses the problems associated with setting levels and a method of ensuring that laser clipping does not occur by using a CR1200R to measure downstream BER (Bit Error Rate).

In a typical 750 MHz cable plant, analog video signals are arranged in 6 MHz spacing from 50 to 550 MHz. The 200 MHz above 550 MHz is typically used for transmission of digital video and cable modem services (e.g. 64 or 256 QAM signals). (See figure 1 showing the typical spectrum)

The levels of the signals should be set so that the peak level of all the analog signals are equal. The average power of the digital signals is 10 dB below the analog peak power. Analog video signals



are usually measured using a peak detector, however, their average power is approximately 10 dB less.

The average power level of an NTSC signal is dependent on the video content. In other words, by setting the peak of the analog signals 10 dB higher than the average power of the digital signals, the average power of all the signals is approximately the same. Many systems have opted to set the digital levels 7 dB below the analog video. This is done at the expense of the analog signal C/N, but could be a worthwhile compromise, particularly in systems running 256-QAM. The C/N



ratio is reduced one dB for each dB the carrier level is lowered, but improves the distortion performance, critical to good BER performance, on Digital signals is improved by 2 dB for every dB change in analog signal level. Note that for the total power level, the sum of all carriers, to remain the same (maximum allowed to not over modulate the laser), the video carrier levels will be set a little low to allow the digital levels to be set higher.

The power handling capacity of amplifiers and lasers is specified in terms of the power level of each carrier and the number of carriers expected. If your system uses fewer channels, the level may be raised without overdriving the laser. If you use more channels than specified, you must reduce the

levels to arrive at the same specified total power. The analog channels and the digital channels shown in the spectrum display of figure 1 all have approximately the same average power level.

When setting levels be sure that the instrument is properly configured to measure **Peak power level on Analog signals and Average power level on Digital signals.**

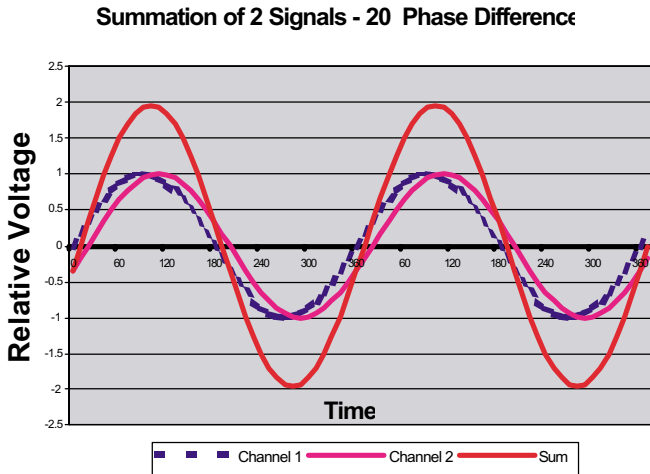

Figure 2

The other consideration is properly setting the modulation on the downstream laser. Lasers operate linearly over a wide range of input levels, but if overdriven, will clip the signal. Since all the signals driving the laser (both analog and digital) are summed together, there is the potential for the peak voltage of the combined signals driving the laser to all peak simultaneously. (See Figure 2). This would be analogous to synchronous modulation. Systems rarely use synchronous modulation, but since the modulation is asynchronous, the phase relationship between all of the carrier's modulation will cause the total power to vary as the timing between the sync peaks varies with time. In practice, the probability of the all the peaks of the individual signals combining in such a way to produce that peak is very slim. The question is raised, however, about how to appropriately adjust the modulation level of the laser.

In regard to setting the laser's modulation level, the total input power level is much more important than the individual carrier levels. Properly setting individual channel levels is important to individual channel performance, however the total power is the key factor in setting the laser's modulation level. Altering the slope or frequency response of an RF pre-amp driving the laser will significantly affect the laser's modulation index. Minor single channel tweaks of a dB at the modulator will have virtually no effect, but

adjusting the tilt or overall gain by 1 dB could have a significant impact. Before setting the modulation index (input power levels to your laser), be sure that the headend composite signals are checked and set correctly at the combiner test point and tweaked in at the laser input test point. The laser input will typically have fine adjustments for level and tilt to compensate for small errors in the combining process and cable losses between the combiner, pre-amp and laser input.

Research has shown that as the modulation index of the laser is increased, distortion will cause the BER of the digital signals to increase before CSO or CTB distortion is visible in the analog signals. In fact, a 1 dB increase in the OMI (optical modulation index) can cause a 600-fold increase in BER, once the laser is operating in its non-linear region. Even as the digital performance starts to degrade, the analog picture quality actually improves, since driving the laser harder increases the C/N ratio.

In order to achieve optimum performance and ensure the laser is not overdriven, it is recommended that the BER of one of the downstream signals be monitored at the RF test point of an optical receiver, while the adjustment is being made. (See Figure 3). The level of the laser should be increased until the BER starts to degrade (e.g. PRE FEC BER goes from $<1.0 \times 10^{-9}$ to 7.6×10^{-8}). Then back the drive to the laser off until the BER goes down again. Observe the measurement for several seconds to be sure the level is not set on an anomaly and back the level down another dB to provide a safe margin of insurance against the effect of asynchronous modulation on multiple carriers.



Figure 3

It is important to monitor the Pre-FEC BER where errors are not yet corrected by the Reed Solomon Forward Error Correction (FEC) software. Monitoring Post-FEC BER would allow laser clipping to create errors, which would be hidden by the error correction. In the CR1200R constellation display shown in figure 3 above, the Pre-FEC BER is 4.8×10^{-7} and the Post-FEC BER is 9.5×10^{-8} .

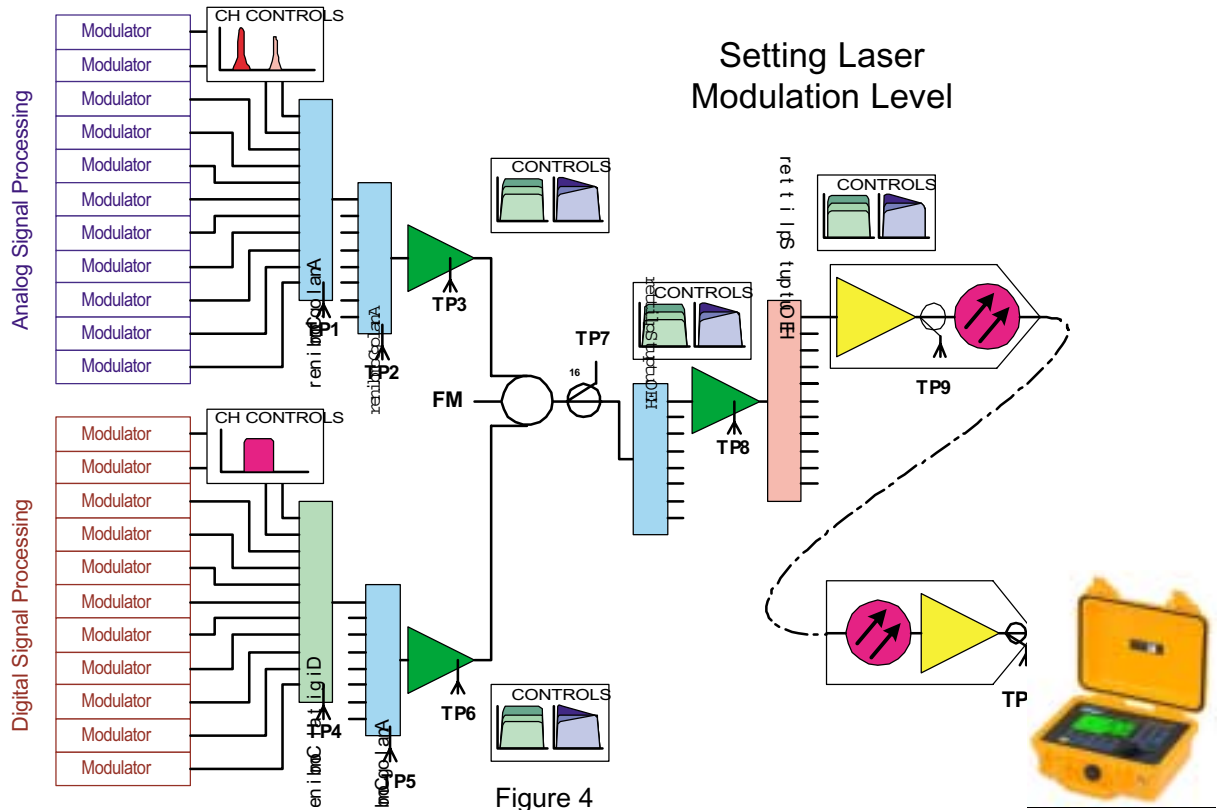

An Example:

Headend configurations vary somewhat from one system to another and will each require a slightly different alignment procedure based on the signals carried and the combining network employed. The example shown above can be adapted easily to any headend configuration. In this example the analog signals are all combined with amplification following the combiners, digital signals are similarly combined, and the analog and digital signals are combined. The composite headend signal is then split, amplified and feed to the optical lasers. This architecture provides independent controls for the analog signal level, digital signal level and overall level and frequency response control. Since overdriving the laser will create serious distortions, it is a good idea to monitor the laser input to be sure that adjustments to the other equipment will not significantly increase the level driving the laser during the setup process. You may want to set the laser drive 2 db low until the other adjustments are completed.

Procedure: (Refer to Figure 4 above)

1. Monitoring TP2, set the output of each analog modulator to the appropriate level typically set the overall output level and then adjust the audio carrier differential.
2. Monitoring TP7, adjust the gain and slope of the analog combining amplifier to provide the correct level and frequency response.
3. Monitoring TP5, set the output level (average) of each digital modulator to the appropriate level.
4. Monitoring TP7, adjust the gain and slope of the digital combining amplifier to provide the correct level and frequency response at the HE test point.
5. Monitoring TP9, adjust the gain and slope of the output splitting amplifier (s) to provide the correct level and frequency response at the input to the laser (s). Repeat if multiple amplifiers are used.
6. Monitoring the signal level at TP9, adjust the laser's gain (or input drive level), while monitoring the BER of the highest digital channel at TP10. (See figure above). The input level of the laser should be increased until the BER starts to degrade (e.g. PRE FEC BER goes from $<1.0 \times E^{-9}$ to $7.6 \times E^{-8}$). Back the drive to the laser off 1 to 2 dB at TP9 lower than the point where the BER drops back down again. Repeat for each laser.
7. Similarly check the lowest digital channel, while monitoring the BER, adjust the slope and repeat the process. Minor touchup may be required due to interaction between the slope and gain controls.
8. Verify the analog signal levels are within 1 dB of their targeted level at the laser test point TP9.

Repeat steps 5 through 8 if large adjustments are required.

Estimating Headend Signal Levels

It may be helpful to estimate the signal levels that you should expect at various test points in the Headend. Work your way back from the laser calculating the target level, be sure to consider that there will be some variation between outputs on multiple output splitters and combiners. For instance in our example, the laser requires +15 dBmV/channel and our test point has 5 dB loss from the input. Our 12 way splitter has 16 dB loss with a 20 dB TP, our 8 way has 12 dB of loss with a 20 dB TP, our 3 way will have 7 dB of loss, we expect 2 dB of cable loss and our amplifiers will each have a maximum of 20 dB gain. Variations in specifications on all of the components can build up to several dB, so we should start out with our output level a little on the low side. Set the analog modulators for +40 dBmV (peak) video and +25 dBmV audio carrier levels. The digital side would be about 10 dB lower or +30 dBmV (average) for 64 QAM signals and +33 dBmV (average) for 256-QAM signals.

1. The analog level at TP9 should be approximately 10 dBmV (15 dBmV-5 dB TP loss).
2. The digital level at TP9 should be approximately 0 dBmV (5 dBmV-5 dB TP loss).
3. The digital level at TP7 should be approximately -2 dBmV (-2=5+16-20+12-16+1).
4. The digital level at TP5 should be approximately 18 dBmV (2=-2+16+7+1-20-20).
5. The digital level at the modulator TP (-20 dB) should be approximately 10 dBmV.
6. The analog level at TP7 should be approximately 8 dBmV (8=15+16-20+12-16+1).
7. The analog level at TP2 should be approximately 8 dBmV (-8=8+16+7+1-20-20).
8. The analog level at the modulator TP (-20 dB) should be approximately 20 dBmV.



By setting these target levels, our laser input should have enough range to allow us to precisely set the proper laser modulation index.

BER Targets

Recommended Pre-FEC BER and Post-FEC BER measurements at various system locations are provided in the chart below.

Location	Pre-FEC BER	Post-FEC BER
CMTS or Modulator	0×10^{-0}	0×10^{-0}
Laser	1×10^{-9}	0×10^{-0}
Node	1×10^{-8}	0×10^{-0}
Drop or End-of-Line	1×10^{-7}	1×10^{-9}